



- High Accuracy
- Broad Bandwidth
- Low Zero-drift

Shenzhen Hangzhi Precision Electronics Co. Ltd.

## HIT300 Hall-Substituting Current Transducer

HIT300 has a high gain and measurement accuracy in the full bandwidth range, due to the application of the multi-point zero-flux technology system and high-frequency ripple sensing channel on top of currently existing DC sensor technology.

The multi-point zero-flux technology system secures the high accuracy by utilizing the technology combination of exciting magnetic flux closed-loop control, self-excited magnetic flux gate and multi-closed-loop control that realizes the closed-loop control between excitation magnetic flux and AC/DC magnetic flux generated by primary current, while the high-frequency ripple sensing channel allows the sensor to have the high performance over the full bandwidth range.

### Product photo

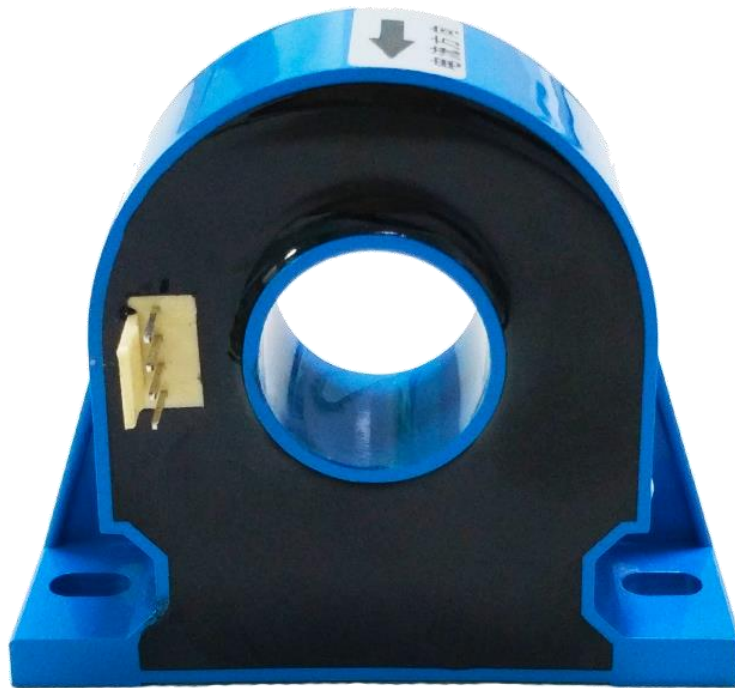

#### SHENZHEN HANGZHI PRECISION ELECTRONICS CO. LTD

Add: Rm 531, Building B, Huayuan Hi-Tech Innovation Park,  
Baoyuan Road, Bao'an District, Shenzhen, China P.R.  
Email: sales@hangzhicn.com Technical support: info@hangzhicn.com  
Tel: +86(0)755-8259 3440 Website: www.hangzhicn.com



- High Accuracy
- Broad Bandwidth
- Low Zero-drift

Shenzhen Hangzhi Precision Electronics Co. Ltd.

## Key Technologies

- ◇ Excitation closed-loop control technology
- ◇ Self-excitation demagnetization technology
- ◇ Multi-point zero-flux technology
- ◇ Temperature control compensation technology
- ◇ Multi-range automatic switching technology

## Features

- ◇ Insulated measurement between primary and secondary side
- ◇ Excellent linearity and accuracy
- ◇ Extremely low temperature drift
- ◇ Extremely low zero drift
- ◇ Broad bandwidth and short response time
- ◇ Strong anti-electromagnetic interference

## Application Domain

- ◇ Medical Equipment: Scanner, MRI
- ◇ Power industry: Converter, Inverter
- ◇ Renewable Energy: Photovoltaic, Wind energy
- ◇ Testing Instrument: Power analyzer, High-precision power supply
- ◇ Smart Power Grid: Power generation and battery monitoring, Medium low voltage substation
- ◇ Industry Control: Industrial motor drive, UPS, Welding, Robot, Hoist, Elevator, Ski lift
- ◇ Rail Transit: EMU, Metro, Trolley car
- ◇ Ship: Electric driven ship
- ◇ Car: Electric car

## Electrical Performance

Parameter	Symbol	Measuring Conditions	Min	Typ	Max	Unit
Primary nominal direct current	$I_{PN\_DC}$	—	—	±300	—	Adc
Primary nominal alternating current*	$I_{PN}$	—	—	212	—	Aac
Primary overload current	$I_{PM}$	1 Minute	—	—	±360	Adc
Operating voltage	$V_C$	—	±14.2	±15	±15.8	V
Power consumption current	$I_{PWR}$	Rated primary current	±30	±130	±150	mA
Current ratio	$K_N$	Input : Output	3000:1	3000:1	3000:1	—
Rated output current	$I_{SN}$	Rated primary current	—	±0.1	—	A
Secondary burden resistance	$R_M$	—	0	10	20	Ω

\* refers to AC effective value

### SHENZHEN HANGZHI PRECISION ELECTRONICS CO. LTD

Add: Rm 531, Building B, Huayuan Hi-Tech Innovation Park,  
Baoyuan Road, Bao'an District, Shenzhen, China P.R.  
Email: sales@hangzhicn.com Technical support: info@hangzhicn.com  
Tel: +86(0)755-8259 3440 Website: www.hangzhicn.com



- High Accuracy
- Broad Bandwidth
- Low Zero-drift

Shenzhen Hangzhi Precision Electronics Co. Ltd.

## Accuracy Measurement

Parameter	Symbol	Measuring Conditions	Min	Typ	Max	Unit
Accuracy	X <sub>G</sub>	Input direct current, full temperature range	—	—	500	ppm
Linearity	ε <sub>L</sub>	Full scale	—	—	50	ppm
Temperature Coefficient	T <sub>C</sub>	—	—	—	50	ppm/K
Zero offset current	I <sub>O</sub>	@25°C	—	—	±5	μA
Zero offset current	I <sub>OT</sub>	Full temperature range	—	—	±10	uA
Dynamic response time	t <sub>r</sub>	di/dt=100A/us, rised to 90%I <sub>PN</sub>	—	1	—	us
Current change rate	di/dt	—	100	—	—	A/us
Frequency bandwidth (-3dB)	F	—	0	—	100	kHz

## Safety Characteristics

Parameter	Symbol	Measuring Conditions	Value	Unit
Insulation voltage / Between primary and secondary sides	V <sub>d</sub>	50Hz, 1min	5	KV
Transient isolation withstand voltage / Between primary and secondary sides	V <sub>w</sub>	50us	10	KV
Creepage distance / Between the primary and the outer shell	dC <sub>p</sub>	—	11	mm
Clearance distance / Between the primary and the outer shell	dC <sub>i</sub>	—	11	mm
Comparative tracking index	CTI	IEC-60112	275	V

## General Characteristics

Parameter	Symbol	Measuring Condition	Min	Typ	Max	Unit
Ambient operating temperature	T <sub>A</sub>	—	-40	—	+80	°C
Storage temperature range	T <sub>s</sub>	—	-55	—	+95	°C
Relative humidity	RH	—	20	—	80	%
Mass	M	—	—	91.5±1.5	—	g

### SHENZHEN HANGZHI PRECISION ELECTRONICS CO. LTD

Add: Rm 531, Building B, Huayuan Hi-Tech Innovation Park,  
Baoyuan Road, Bao'an District, Shenzhen, China P.R.  
Email: sales@hangzhicn.com Technical support: info@hangzhicn.com  
Tel: +86(0)755-8259 3440 Website: www.hangzhicn.com



- High Accuracy
- Broad Bandwidth
- Low Zero-drift

Shenzhen Hangzhi Precision Electronics Co. Ltd.

## Operating Status Instructions

When power supply is normal and the primary current is within the specified measurement range, the secondary and primary currents are in proportional. If the primary current is over the specified measurement range, the transducers will be in overload mode, and the secondary and primary currents are not in proportional. The secondary and primary currents will return to be in proportional when the primary current recovers to the specified measurement range.

## Connection system

### 1. Pin function definition of phoenix terminal

Pin No.	1 V+	2 V-	3 OUT	4 GND
Definition	<b>+15V Supply</b>	<b>-15V Supply</b>	<b>I_Output</b>	<b>GND</b>

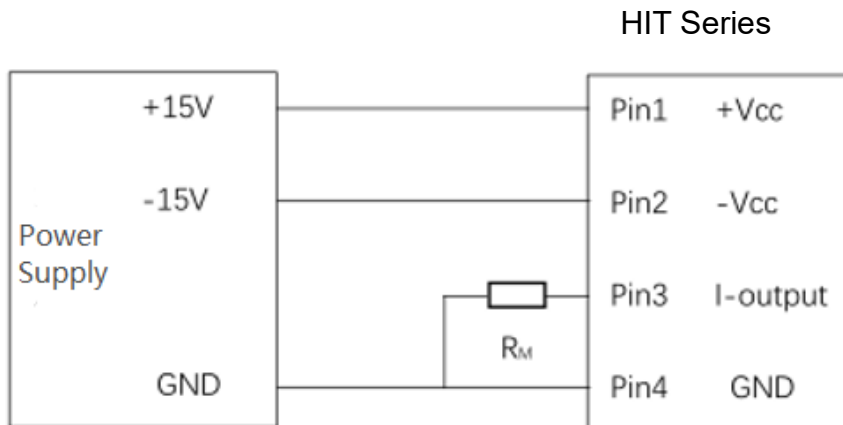

Test instruction:

The primary current  $I_P$  can be obtained by measuring the test current  $I_s$  flowing through  $R_M$  or the voltage  $U_R$  across  $R_M$ :

$$I_P = K_N * I_S = K_N * (U_R/R_M)$$



- High Accuracy
- Broad Bandwidth
- Low Zero-drift

Shenzhen Hangzhi Precision Electronics Co. Ltd.

## Dimensions

Unit: mm

