

AIT400-SG High-Precision Current Transducer

AIT400-SG has a high gain and measurement accuracy in the full bandwidth range, due to the application of the multi-point zero-flux technology system and high-frequency ripple sensing channel on top of currently existing DC sensor technology.

The multi-point zero-flux technology system secures the high accuracy by utilizing the technology combination of exciting magnetic flux closed-loop control, self-excited magnetic flux gate and multi-closed-loop control that realizes the closed-loop control between excitation magnetic flux and AC/DC magnetic flux generated by primary current, while the high-frequency ripple sensing channel allows the sensor to have the high performance over the full bandwidth range.

Product photo



SHENZHEN HANGZHI PRECISION ELECTRONICS CO. LTD

Add: Rm 531, Building B, Huayuan Hi-Tech Innovation Park,
Baoyuan Road, Bao'an District, Shenzhen, China P.R.
Email: sales@hangzhicn.com Technical support: info@hangzhicn.com
Tel: +86(0)755-8259 3440 Website: www.hangzhicn.com



- High Accuracy
- Broad Bandwidth
- Low Zero-drift

Shenzhen Hangzhi Precision Electronics Co. Ltd.

Key Technologies

- ◇ Excitation closed-loop control technology
- ◇ Self-excitation demagnetization technology
- ◇ Multi-point zero-flux technology
- ◇ Temperature control compensation technology
- ◇ Multi-range automatic switching technology

Features

- ◇ Insulated measurement between primary and secondary side
- ◇ Excellent linearity and accuracy
- ◇ Extremely low temperature drift
- ◇ Extremely low zero drift
- ◇ Broad band and low response time
- ◇ Strong anti-electromagnetic interference

Application Domain

- ◇ Medical Equipment: Scanner, MRI
- ◇ Power industry: Converter, Inverter □
- ◇ Renewable Energy: Photovoltaic, Wind energy
- ◇ Testing Instrument: Power analyzer, High-precision power supply
- ◇ Smart Power Grid: Power generation and battery monitoring, Medium low voltage substation
- ◇ Industry Control: Industrial motor drive, UPS, Welding, Robot, Hoist, Elevator, Ski lift
- ◇ Rail Transit: EMU, Metro, Trolley car □
- ◇ Ship: Electric driven ship
- ◇ Car: Electric car

Electrical Performance

Parameter	Symbol	Measuring Conditions	Min	Typ	Max	Unit
Primary nominal direct current	I_{PN_DC}	—	—	±400	—	Adc
Primary nominal RMS current*	I_{PN_AC}	—	—	282	—	Aac
Primary current, measuring range	I_{PM}	—	—	—	±480	Adc
Power supply voltage DC	U_C	—	±14.2	±15	±15.8	V
Power consumption current	I_C	Rated primary current	±30	±230	±270	mA
Conversion ratio	K_N	Primary/secondary	1:2000	1:2000	1:2000	—
Secondary nominal RMS current	I_{SN}	Rated Primary current	—	±0.2	—	A
Secondary burden resistance	R_M	See Fig. 1	0	5	12	Ω

* refers to AC effective value

SHENZHEN HANGZHI PRECISION ELECTRONICS CO. LTD

Add: Rm 531, Building B, Huayuan Hi-Tech Innovation Park,
Baoyuan Road, Bao'an District, Shenzhen, China P.R.
Email: sales@hangzhicn.com Technical support: info@hangzhicn.com
Tel: +86(0)755-8259 3440 Website: www.hangzhicn.com



- High Accuracy
- Broad Bandwidth
- Low Zero-drift

Shenzhen Hangzhi Precision Electronics Co. Ltd.

Accuracy Measurement

Parameter	Symbol	Measuring Conditions	Min	Typ	Max	Unit
Accuracy	X _G	Input direct current, 25±20°C	—	—	10	ppm
Linearity error	ε _L	—	—	—	2	ppm
Offset temperature coefficient	T _C	—	—	—	0.1	ppm/K
Offset stability over time	T _T	—	—	—	0.2	ppm/month
Power supply interference	T _V	—	—	—	1	ppm/V
Zero offset current	I _O	@25°C	—	—	1 (can be adjusted to zero by users)	ppm
Ripple current	I _N	DC-10Hz	—	—	0.5	ppm
Step response time to 90%I _{PN_DC}	t _r	di/dt of 100A/μs	—	—	1	μs
Current change rate	di/dt	—	100	—	—	A/μs
Frequency bandwidth (-3dB)	BW	—	0	—	500	kHz
Zero offset current	I _{OT}	Full temperature range	—	—	±5	μA

Safety Characteristics

Parameter	Symbol	Measuring Conditions	Value	Unit
Insulation voltage / Between primary and secondary	U _d	50Hz, 1min	5	KV
Impulse withstand voltage / Between primary and secondary	U _w	50μs	10	KV
Creepage distance / Between primary and shield	d _{CP}	—	11	mm
Clearance distance / Between primary and shield	d _{CI}	—	11	mm
Comparative tracking index	CTI	IEC-60112	600	V

General Characteristics

Parameter	Symbol	Measuring Conditions	Min	Typ	Max	Unit
Ambient operating temperature	T _A	—	-40	—	+85	°C
Ambient storage temperature	T _S	—	-40	—	+85	°C
Relative humidity	RH	—	20	—	80	%
Mass	M	—	—	520±50	—	g

SHENZHEN HANGZHI PRECISION ELECTRONICS CO. LTD

Add: Rm 531, Building B, Huayuan Hi-Tech Innovation Park,
Baoyuan Road, Bao'an District, Shenzhen, China P.R.
Email: sales@hangzhicn.com Technical support: info@hangzhicn.com
Tel: +86(0)755-8259 3440 Website: www.hangzhicn.com



- High Accuracy
- Broad Bandwidth
- Low Zero-drift

Shenzhen Hangzhi Precision Electronics Co. Ltd.

Burden Resistor Instructions

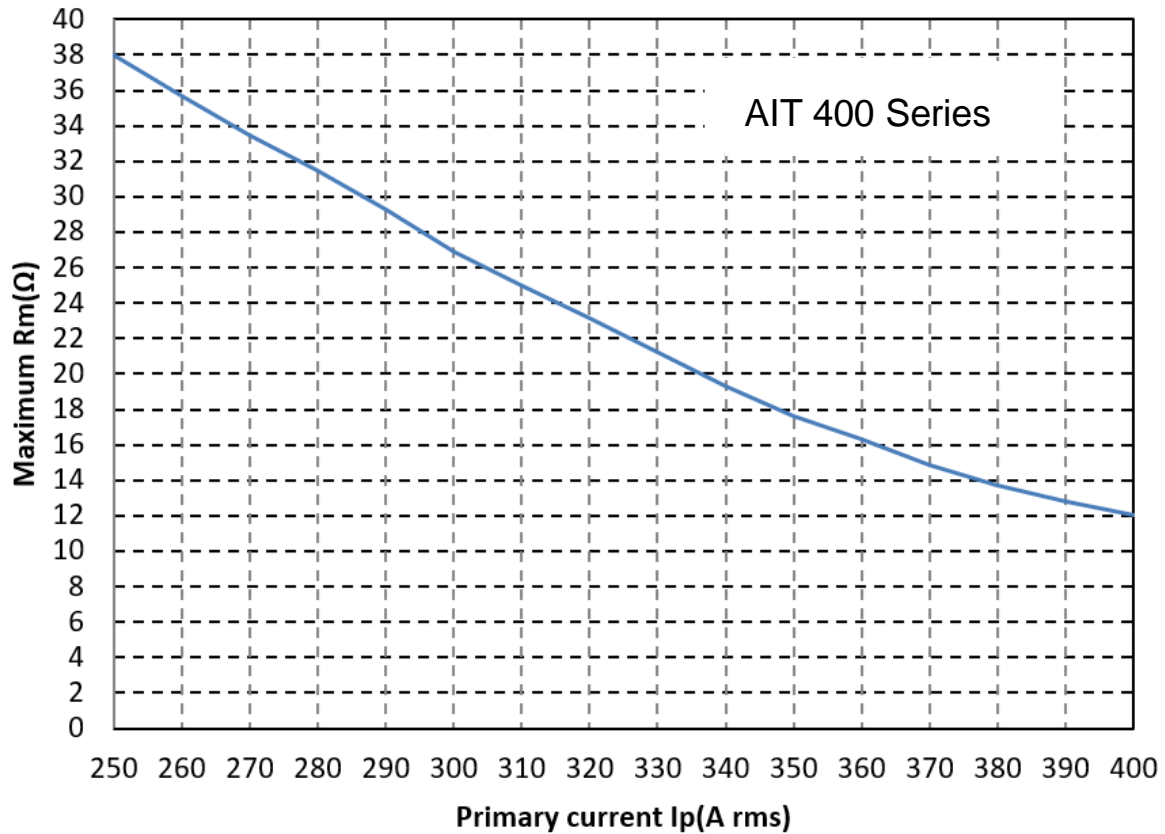

Operating Status Instructions

◇ Normal status:

The green indicator is on when the device is running normally:

After the device is powered on, the green indicator is on when the device is running normally, and the 3rd pin and 8th pin of D-Sub9 interface are connected together.

◇ Fault status:

The green light will be off when the transducer is in fault mode.

Trouble-shooting:

- When the green light is off, the power supply should be checked as the first step;
- If the power supply is normal, then the primary current is over the specified measurement range and the transducers will be in overload mode.

In this mode, the transducers will be working in non-zero flux mode, that the secondary current remains at specified maximum output, the secondary and primary currents are not in proportional and the connection between pin 3 & 8 of the DB9 interface will be off.

SHENZHEN HANGZHI PRECISION ELECTRONICS CO. LTD

Add: Rm 531, Building B, Huayuan Hi-Tech Innovation Park,
Baoyuan Road, Bao'an District, Shenzhen, China P.R.
Email: sales@hangzhicn.com Technical support: info@hangzhicn.com
Tel: +86(0)755-8259 3440 Website: www.hangzhicn.com



- High Accuracy
- Broad Bandwidth
- Low Zero-drift

Shenzhen Hangzhi Precision Electronics Co. Ltd.

Connection system

1. D-Sub9 Connection terminal pin function definition

Pin No.	1	2、7	3	4	5	6	8	9
Definition	I_Output COM	N.C	Interlock(-)	GND	-15V Supply	I_Output	Interlock(+)	+15V Supply

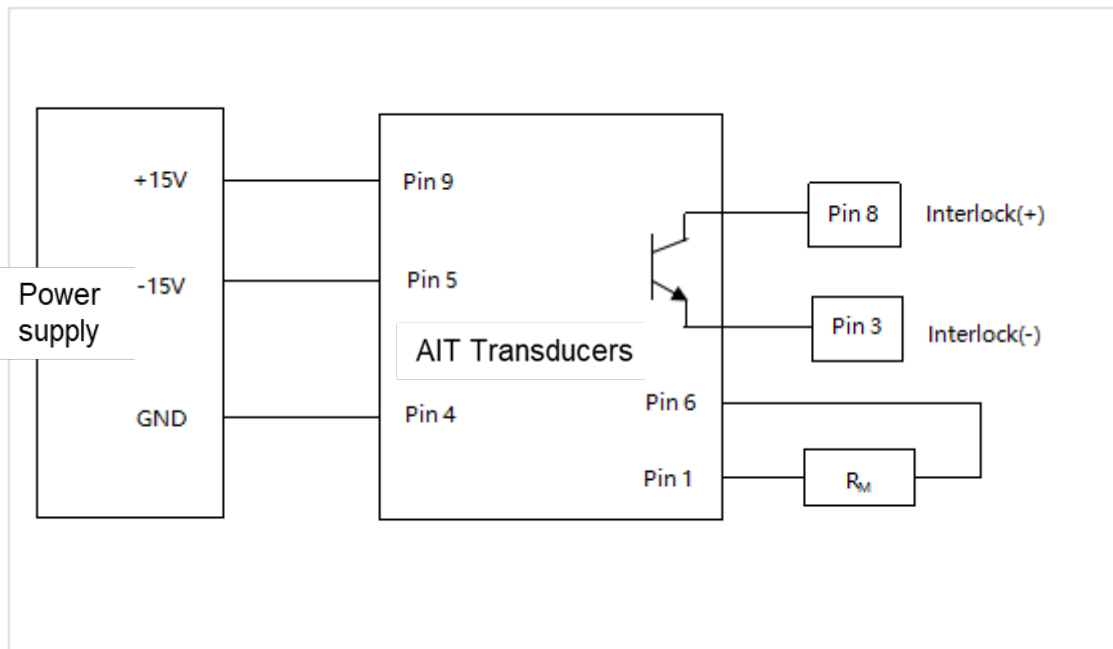

Test instruction:

The primary current I_P can be obtained by measuring the test current I_S flowing through R_M or the voltage U_R across R_M :

$$I_P = K_N * I_S = K_N * (U_R/R_M)$$

2. Interlock Port connection description:

There are two types of Interlock Port connection based on users' actual application shown as Fig A and Fig B:



- High Accuracy
- Broad Bandwidth
- Low Zero-drift

Shenzhen Hangzhi Precision Electronics Co. Ltd.

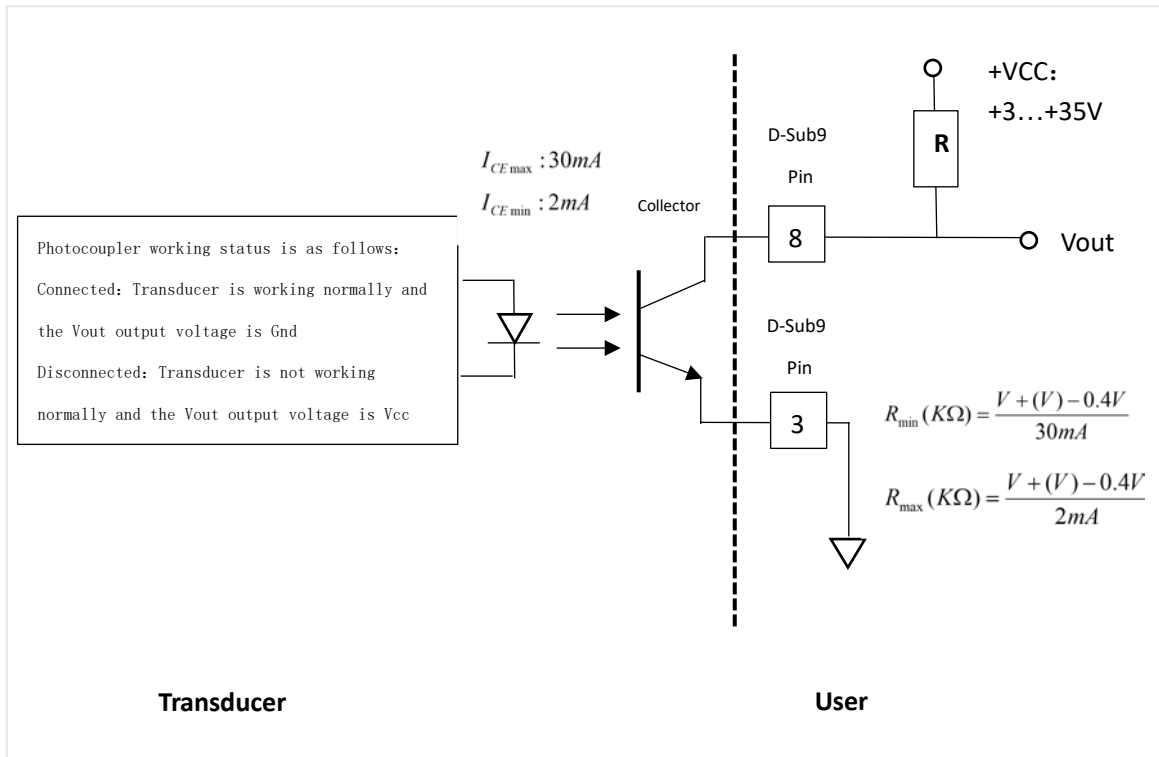

Fig A: Low level output when the transducer is operating normally

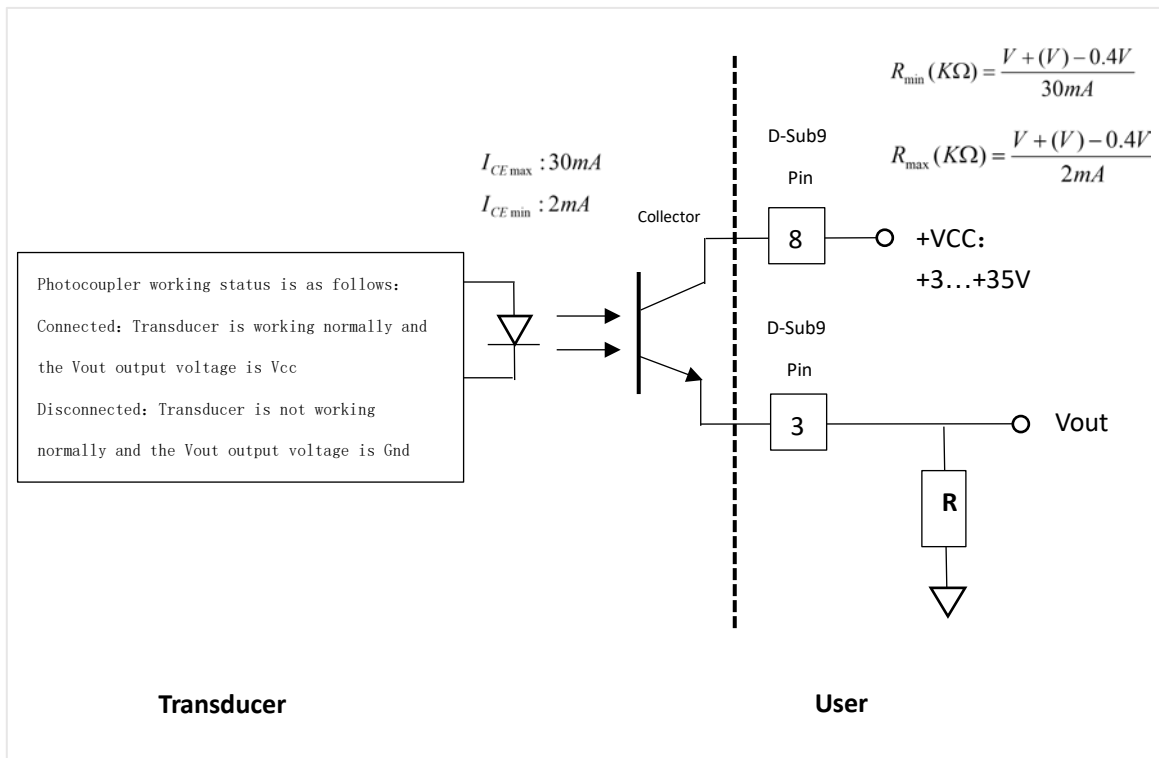

Fig B: High output when the transducer is operating normally



- High Accuracy
- Broad Bandwidth
- Low Zero-drift

Shenzhen Hangzhi Precision Electronics Co. Ltd.

3. The output of the pin Vout in the optocoupler is related to the user-designed circuit, as shown in the following table.

Parameter	Vout	Description
Fig A	<0.2V	The transducer is working normally.
	Vcc	The transducer is working abnormally, i.e., in overload mode or abnormal power supply
	<0.2V	The transducer is working abnormally, i.e., in overload mode or abnormal power supply
Fig B	Vcc	The transducer is working normally.

Dimensions

Unit: mm

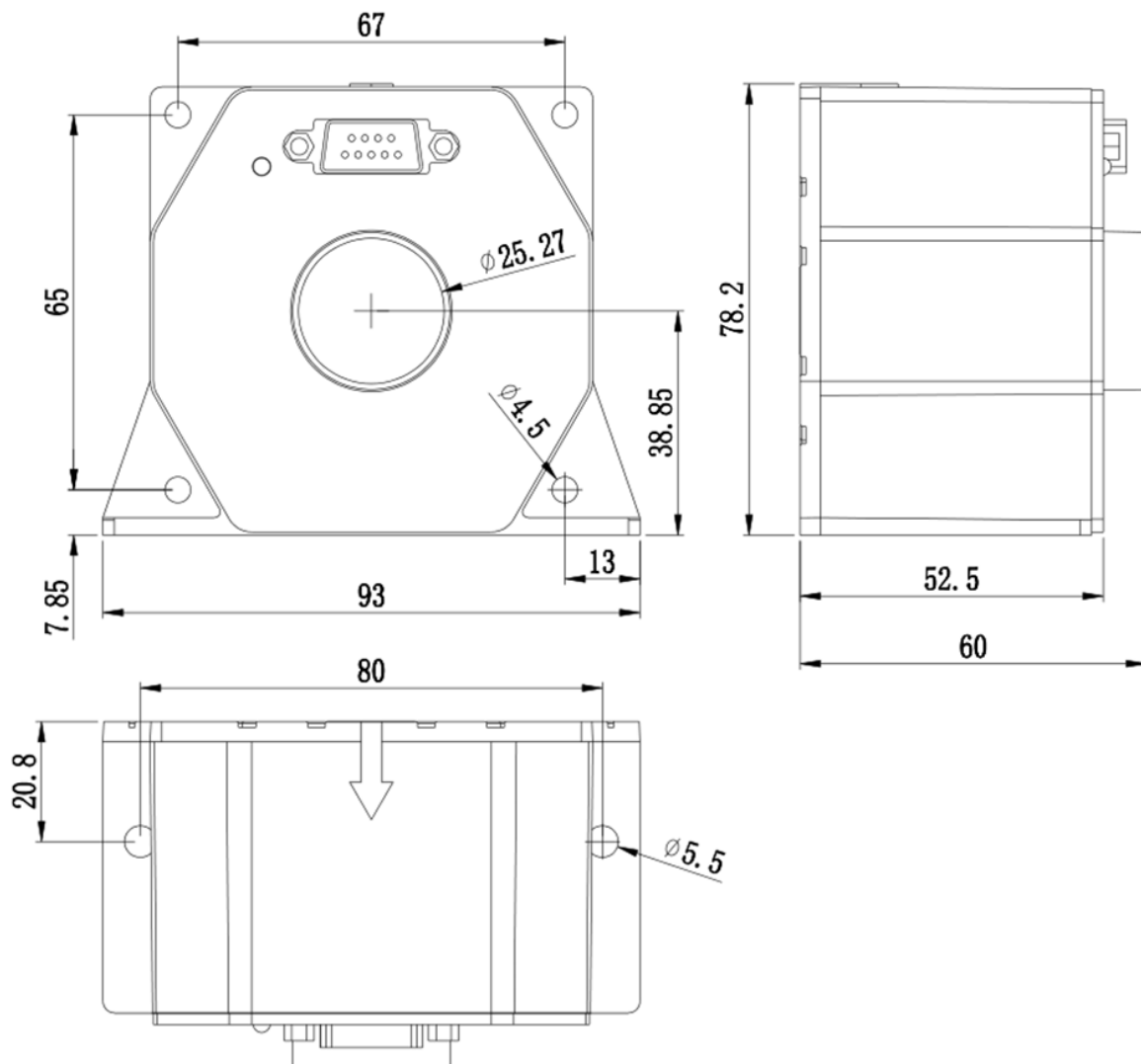

SHENZHEN HANGZHI PRECISION ELECTRONICS CO. LTD

Add: Rm 531, Building B, Huayuan Hi-Tech Innovation Park,
Baoyuan Road, Bao'an District, Shenzhen, China P.R.
Email: sales@hangzhicn.com Technical support: info@hangzhicn.com
Tel: +86(0)755-8259 3440 Website: www.hangzhicn.com